

Latest Innovations

Innovative solutions developed across all areas of technology.

Product Catalogue

Flour and Bran Silo Discharger

- SE-DDB-100/20
- SE-DDB-100/30
- SE-DDB-130/30
- SE-DDB-130/50
- SE-DDB-160/30
- SE-DDB-160/50
- SE-DDB-200/30
- SE-DDB-200/50

Technological Advantages

Across All Markets and Sectors

SE-DDB FLOUR AND BRAN SILO DISCHARGER- APPLICATION OVERVIEW

The SE-DDB Flour and Bran Silo Discharger is specifically developed for reliable and high-capacity discharge of flour, bran, and fine bulk materials from storage silos in modern milling facilities. Designed to handle lightweight and aerated products such as flour and bran, the SE-DDB ensures stable, mass-flow discharge while preventing bridging, arching, and uneven material flow inside the silo cone. Unlike standard vibration units, the SE-DDB model is optimized for flour mill environments where product consistency, hygiene, and continuous operation are critical. Its reinforced discharge structure distributes vibration evenly across the silo outlet, enabling smooth product extraction without damaging flour quality or causing segregation. This ensures uniform downstream feeding to conveying lines, packaging systems, or processing equipment. The machine operates with a balanced vibration assembly that minimizes structural stress on the silo body while maintaining powerful discharge performance. Its energy-efficient drive system reduces power consumption and supports long-term industrial use under heavy production loads. The design also allows integration with flour conveying lines, bran transport systems, packaging units, and bulk loading stations. Manufactured with food-grade construction principles, the SE-DDB features easy-access maintenance points and a compact mounting configuration for seamless installation under existing silos. It reduces downtime, improves plant productivity, and enhances operational safety in flour mills, grain processing plants, and bulk powder handling facilities.

FEATURES & ADVANTAGES

- ▶ Prevents bridging and material blockage inside silos
- ▶ Ensures continuous, uniform, and controlled product discharge
- ▶ Vibration-based system for efficient bulk material flow
- ▶ Heavy-duty construction for industrial operating conditions
- ▶ Low noise and balanced vibration performance
- ▶ Reduces downtime and manual intervention
- ▶ Easy installation under existing silo systems
- ▶ Low maintenance requirements and long service life
- ▶ Energy-efficient operation with reduced operating costs

APPLICATION FIELDS

- ▶ Wheat flour mills
- ▶ Whole wheat flour milling plants
- ▶ Semolina (durum wheat) production lines
- ▶ Pasta flour production facilities
- ▶ Corn flour milling plants
- ▶ Rusk (galeta) flour mills
- ▶ Starch production plants
- ▶ Milling, sifting, and quality control sections
- ▶ Flour packaging lines
- ▶ Flour conveying lines
- ▶ Dusty product and granular material conveying lines
- ▶ Grain silos
- ▶ Grain storage facilities

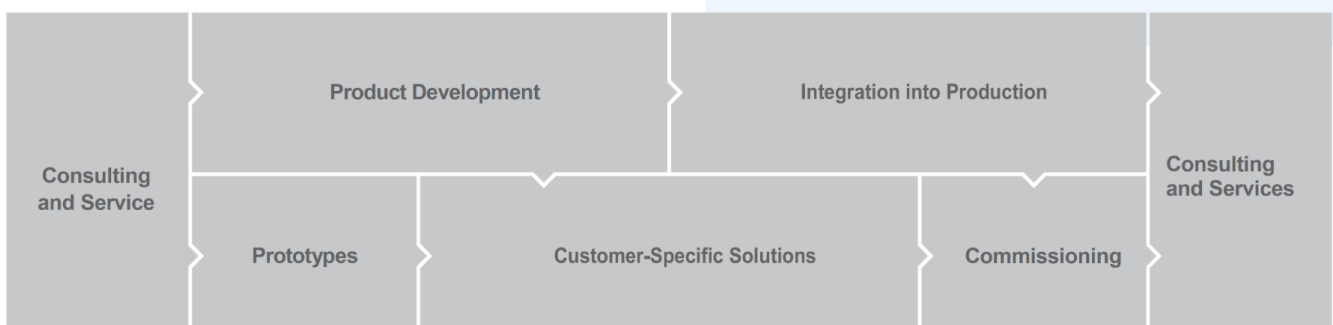

Technical Table

Flour and Bran Silo Discharger

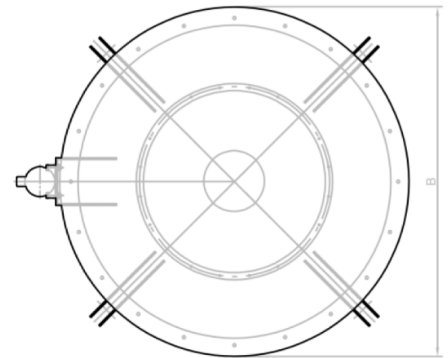
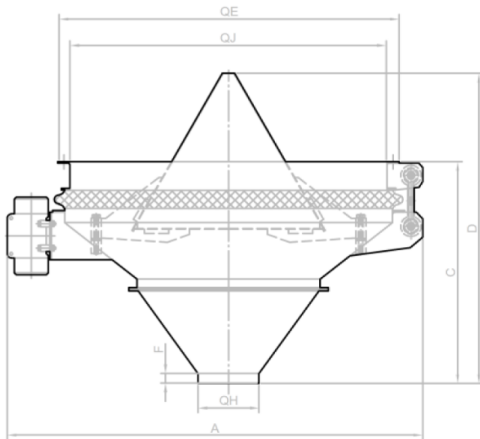
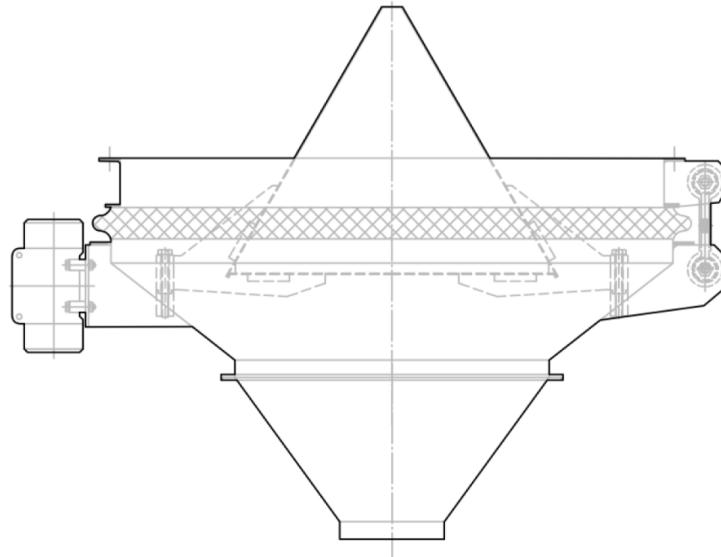

MODEL MODELE	DIMENSIONS mm.								TECHNICAL FEATURES CARACTERISTIQUES TECHNIQUES				
	A	B	C	D	E	ØH	ØJ	F	Motor Moteur Kw	Weights - Poids Kg		Gross volume Volume sous emballage m³	
										Net	Gross Brut		
SE-DDB-100/20	1400	1100	783	983	1058	200	958	30	0,43	244	390	2,5	
SE-DDB-100/30			714	914		300		30			386	2,3	
SE-DDB-130/30	1765	1430	913	1150	1378	300	1258	35	0,55	412	639	4,8	
SE-DDB-130/50			776	1035		500		35			626	4,3	
SE-DDB-160/30	2060	1730	1090	1524	1678	300	1558	40			525	842	8,1
SE-DDB-160/50			953	1386		500		40				830	7,5
SE-DDB-200/30	2470	2130	1246	1524	2090	300	1958	50	0,80	610	1024	11,5	
SE-DDB-200/50			1108	1386		500		50			1010	10,6	

SEDIROGLU GROUP DELIVERS COMPLETE SOLUTIONS ACROSS VARIOUS INDUSTRIES, COMBINING DEEP TECHNICAL EXPERTISE WITH A DIVERSE AND EXTENSIVE PRODUCT RANGE TO MEET A WIDE SPECTRUM OF CUSTOMER NEEDS.

FACING A DEVELOPMENT CHALLENGE? WE PROVIDE THE SOLUTION.
AT SEDIROGLU GROUP, OUR EXPERIENCED R&D TEAM IS COMMITTED TO CONTINUOUS IMPROVEMENT.
MANY INDUSTRY INNOVATIONS HAVE ORIGINATED FROM OUR COMPANY.
WE ARE DRIVEN BY A FORWARD-THINKING MINDSET AND A PIONEERING SPIRIT IN EVERY STEP WE TAKE.

CONTACT – WORLDWIDE

With 12 branches around the world and marketing teams in over 70 countries, we provide you with outstanding service worthy of a technology leader.

We look forward to hearing from you!

<https://sedirolugroup.com/contact>



AT YOUR SERVICE 24/7 – OUR VIRTUAL BOOTH

With impressive features like animated shots, clickable hotspots, and rotatable 3D models, we are confident our online presentations will truly impress you.

<https://sedirolugroup.com/products>



DISCOVER MORE ABOUT THIS PRODUCT

Scan the QR code to access detailed technical specifications, application insights, high-quality visuals, and interactive digital content related to this product.

<https://sedirolugroup.com/products/flour-and-bran-silo-discharger>



HEAD OFFICE:
SEDIROGLU GROUP
Turkey, Çorum
T +90 541 620 03 22
E Mail : info@sedirolu.com
E Mail : info@sedirolugroup.com

www.sedirolugroup.com

Sedirolu
GROUP machine