

## Latest Innovations

Innovative solutions developed  
across all areas of technology.

Product Catalogue

Vibro Silo Discharger

SE-DDA-100/20  
SE-DDA-100/30  
SE-DDA-130/30  
SE-DDA-130/50  
SE-DDA-160/30  
SE-DDA-160/50  
SE-DDA-200/30  
SE-DDA-200/50

# Technological Advantages

## Across All Markets and Sectors

### SE-DDA VIBRO SILO DISCHARGER- APPLICATION OVERVIEW

The SE-DDA Vibro Silo Discharger is engineered to ensure smooth, continuous, and controlled discharge of flour, semolina, grain, and other bulk materials from storage silos in modern milling and industrial processing plants. It is specially designed to prevent material bridging, rat-holing, and compaction inside silos, ensuring uninterrupted product flow and maximum operational efficiency. Operating through controlled vibration technology, the SE-DDA generates uniform movement at the silo outlet, allowing bulk materials to flow evenly without blockages. This system significantly reduces downtime, improves production continuity, and enhances process safety. Its robust construction and balanced vibration mechanism ensure low noise levels, minimal structural stress, and long-term durability under heavy-duty industrial conditions. With its hygienic and compact design, the SE-DDA Vibro Silo Discharger can be easily integrated into flour mills, feed mills, grain storage facilities, starch factories, and other bulk handling systems. The machine supports efficient material handling, reduces manual intervention, and optimizes silo discharge performance while lowering operational costs. The SE-DDA Vibro Silo Discharger enhances material flow reliability, protects product quality, and ensures consistent performance in high-capacity bulk storage applications.

#### FEATURES & ADVANTAGES

- ▶ Prevents bridging and material blockage inside silos
- ▶ Ensures continuous, uniform, and controlled product discharge
- ▶ Vibration-based system for efficient bulk material flow
- ▶ Heavy-duty construction for industrial operating conditions
- ▶ Low noise and balanced vibration performance
- ▶ Reduces downtime and manual intervention
- ▶ Easy installation under existing silo systems
- ▶ Low maintenance requirements and long service life
- ▶ Energy-efficient operation with reduced operating costs

#### APPLICATION FIELDS

- ▶ Wheat flour mills
- ▶ Whole wheat flour milling plants
- ▶ Semolina (durum wheat) production lines
- ▶ Pasta flour production facilities
- ▶ Corn flour milling plants
- ▶ Rusk (galeta) flour mills
- ▶ Starch production plants
- ▶ Milling, sifting, and quality control sections
- ▶ Flour packaging lines
- ▶ Flour conveying lines
- ▶ Dusty product and granular material conveying lines
- ▶ Grain silos
- ▶ Grain storage facilities
- ▶ Cement factories

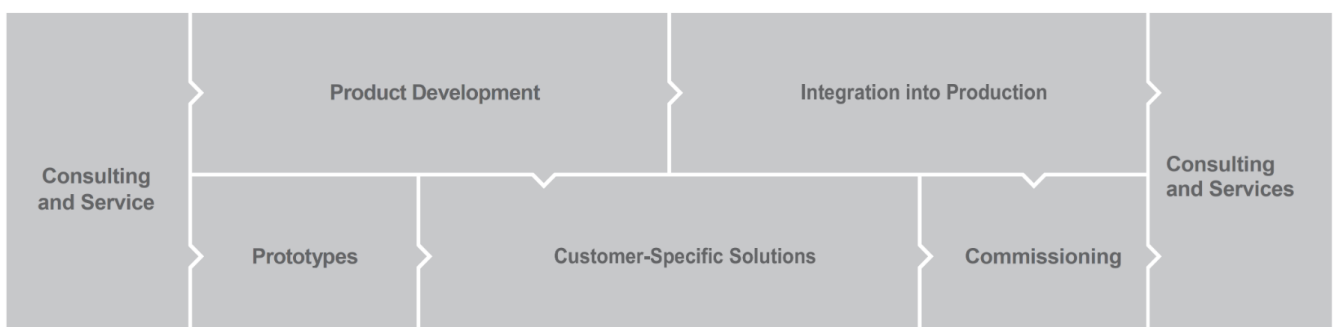

# Technical Table

Wheat and Grain Silo Discharger

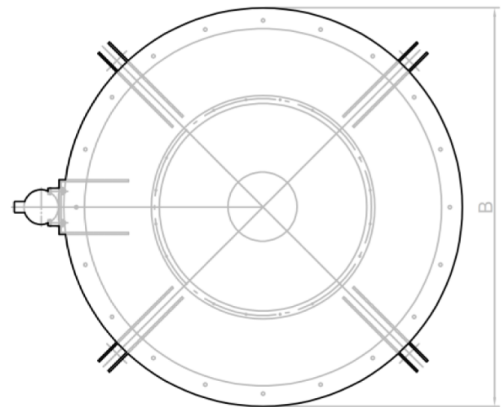
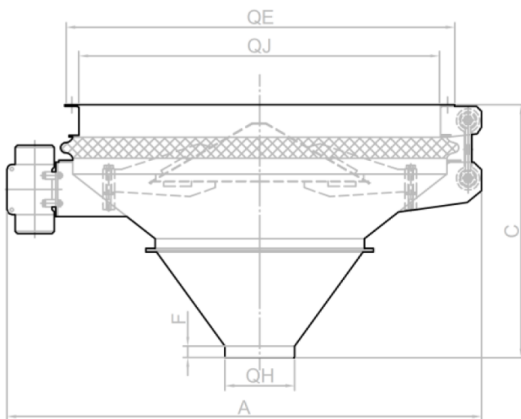
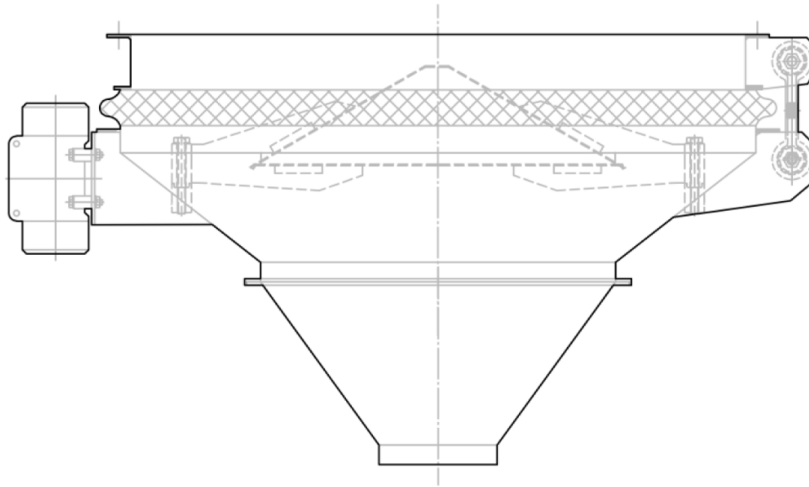

MODEL MODELE	DIMENSIONS mm.								TECHNICAL FEATURES CARACTERISTIQUES TECHNIQUES				
	A	B	C	D	E	ØH	ØJ	F	Motor Moteur Kw	Weights - Poids Kg		Gross volume Volume sous emballage m³	
										Net	Gross Brut		
SE-DDA-100/20	1400	1100	570	783	1058	200	958	30	0,43	225	390	2,5	
SE-DDA-100/30			500	714		300		30			386	2,3	
SE-DDA-130/30	1765	1430	774	913	1378	300	1258	35	0,55	362	639	4,8	
SE-DDA-130/50			637	776		500		35			626	4,3	
SE-DDA-160/30	2060	1730	1010	1090	1678	300	1558	40			430	842	8,1
SE-DDA-160/50			872	953		500		40				830	7,5
SE-DDA-200/30	2470	2130	1010	1246	2090	300	1958	50	0,80	790	1024	11,5	
SE-DDA-200/50			872	1108		500		50			1010	10,6	

# SEDIROGLU GROUP DELIVERS COMPLETE SOLUTIONS ACROSS VARIOUS INDUSTRIES, COMBINING DEEP TECHNICAL EXPERTISE WITH A DIVERSE AND EXTENSIVE PRODUCT RANGE TO MEET A WIDE SPECTRUM OF CUSTOMER NEEDS.

FACING A DEVELOPMENT CHALLENGE? WE PROVIDE THE SOLUTION.  
AT SEDIROGLU GROUP, OUR EXPERIENCED R&D TEAM IS COMMITTED TO CONTINUOUS IMPROVEMENT.  
MANY INDUSTRY INNOVATIONS HAVE ORIGINATED FROM OUR COMPANY.  
WE ARE DRIVEN BY A FORWARD-THINKING MINDSET AND A PIONEERING SPIRIT IN EVERY STEP WE TAKE.

## CONTACT – WORLDWIDE

With 12 branches around the world and marketing teams in over 70 countries, we provide you with outstanding service worthy of a technology leader.

We look forward to hearing from you!

<https://sediroglugroup.com/contact>



## AT YOUR SERVICE 24/7 – OUR VIRTUAL BOOTH

With impressive features like animated shots, clickable hotspots, and rotatable 3D models, we are confident our online presentations will truly impress you.

<https://sediroglugroup.com/products>



## DISCOVER MORE ABOUT THIS PRODUCT

Scan the QR code to access detailed technical specifications, application insights, high-quality visuals, and interactive digital content related to this product.

<https://sediroglugroup.com/products/vibro-silo-discharger>



HEAD OFFICE:  
**SEDIROGLU GROUP**  
Turkey, Çorum  
T +90 541 620 03 22  
E Mail : [info@sediroglu.com](mailto:info@sediroglu.com)  
E Mail : [info@sediroglugroup.com](mailto:info@sediroglugroup.com)

[www.sediroglugroup.com](http://www.sediroglugroup.com)

**Sediroglu**  
GROUP machine