

Latest Innovations

Innovative solutions developed across all areas of technology.

Product Catalogue

Diverter Valve Dual Way

SE-DVD-A-50
SE-DVD-A-70
SE-DVD-A-95
SE-DVD-A-125
SE-DVD-A-135
SE-DVD-A-160

www.sediroglugroup.com

Sediroglu
GROUP machine

Technological Advantages

Across All Markets and Sectors

SE-DVD-A DIVERTER VALVE DUAL WAY- APPLICATION OVERVIEW

The SE-DVD-A DIVERTER VALVE DUAL WAY is engineered to provide precise and efficient material flow direction in pneumatic conveying and gravity-based transfer systems. Designed for flour, semolina, feed, and grain processing plants, this valve enables controlled distribution of bulk materials between two separate conveying lines without interrupting production flow. Manufactured with a robust steel body and precision-machined internal components, the SE-DVD-A ensures airtight sealing, minimal leakage, and smooth switching performance. Its optimized flap mechanism guarantees reliable transition between outlets while maintaining product integrity and preventing cross-contamination. The system is suitable for integration into automated production lines and can be operated manually or pneumatically depending on plant configuration. The SE-DVD-A DIVERTER VALVE DUAL WAY improves operational flexibility by allowing fast route changes during product transfer, silo filling, or multi-line distribution processes. Its durable construction supports continuous industrial operation, reducing maintenance requirements and minimizing downtime. This solution enhances process efficiency, ensures stable material flow control, and supports consistent performance in modern milling and bulk handling facilities.

FEATURES & ADVANTAGES

- ▶ Precise and secure product flow diversion between multiple pipeline routes
- ▶ Airtight sealing system minimizing product leakage and dust emission
- ▶ Robust cast body design for long-term industrial use
- ▶ Smooth internal surface ensuring uninterrupted material flow
- ▶ Pneumatic or manual actuator options for flexible operation
- ▶ Compact structure suitable for limited installation spaces
- ▶ Hygienic design compatible with food-grade processing lines
- ▶ Low maintenance requirements and reliable long service life

APPLICATION FIELDS

- ▶ Wheat flour mills
- ▶ Whole wheat flour milling plants
- ▶ Semolina (durum wheat) production lines
- ▶ Pasta flour production facilities
- ▶ Corn flour milling plants
- ▶ Rusk (galeta) flour mills
- ▶ Starch production plants
- ▶ Milling, sifting, and quality control sections
- ▶ Flour packaging lines
- ▶ Flour conveying lines
- ▶ Dusty product and granular material conveying lines

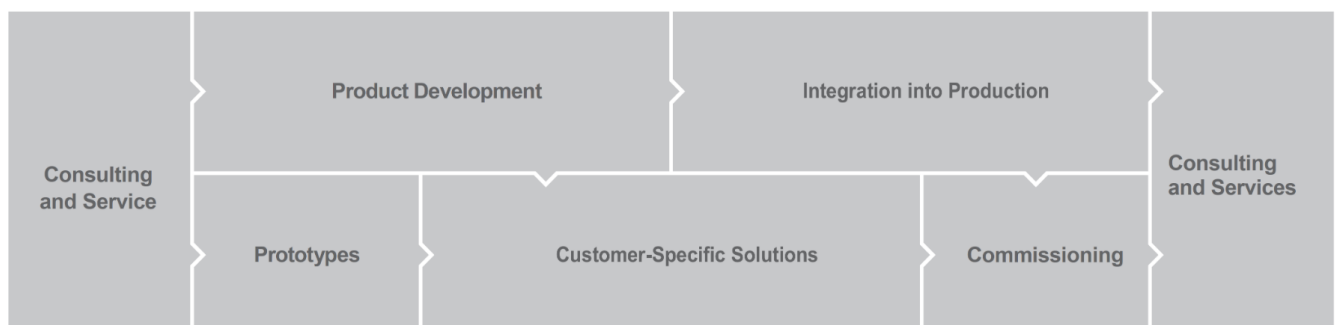

Technical Table

Diverter Valve Dual Way

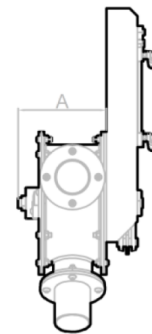
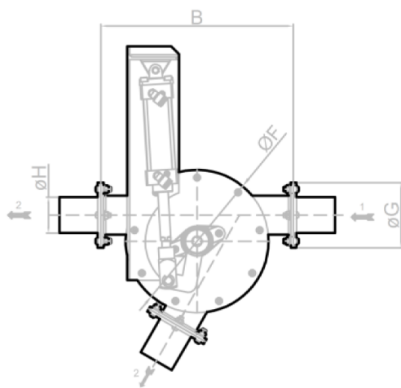
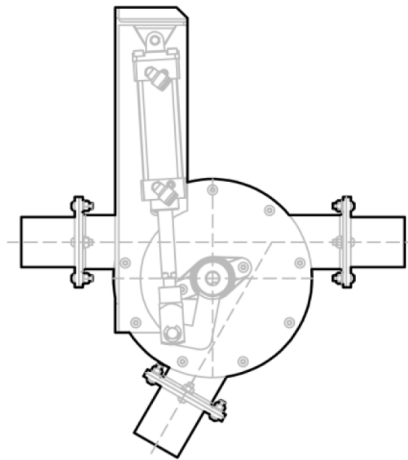

Sediroglu
GROUP machine

MODEL MODELE	DIMENSIONS mm.					TECHNICAL FEATURES CARACTERISTIQUES TECHNIQUES		
	A	B	ØF	øG	ØH	Weights - Poids Kg		Volume sous Gross volume emballage m ³
						Net	Gross-Brut	
SE-DVD-A-50	107	251	179	110	42 46 51 57	36	37	0.1
SE-DVD-A-70	126	310	225	130	63 70 76 83	40	42	0.1
SE-DVD-A-95	154	401	287	165	95 102	61	63	0.12
SE-DVD-A-125	194	492	370	195	108 119 125	98	101	0.14
SE-DVD-A-135	202	484	380	215	133 150	132	135	0.18
SE-DVD-A-160	258	618	485	274	163 170	171	174	0.22

SEDIROGLU GROUP DELIVERS COMPLETE SOLUTIONS ACROSS VARIOUS INDUSTRIES, COMBINING DEEP TECHNICAL EXPERTISE WITH A DIVERSE AND EXTENSIVE PRODUCT RANGE TO MEET A WIDE SPECTRUM OF CUSTOMER NEEDS.

FACING A DEVELOPMENT CHALLENGE? WE PROVIDE THE SOLUTION.
AT SEDIROGLU GROUP, OUR EXPERIENCED R&D TEAM IS COMMITTED TO CONTINUOUS IMPROVEMENT.
MANY INDUSTRY INNOVATIONS HAVE ORIGINATED FROM OUR COMPANY.
WE ARE DRIVEN BY A FORWARD-THINKING MINDSET AND A PIONEERING SPIRIT IN EVERY STEP WE TAKE.

CONTACT – WORLDWIDE

With 12 branches around the world and marketing teams in over 70 countries, we provide you with outstanding service worthy of a technology leader.

We look forward to hearing from you!

<https://sedirolugroup.com/contact>



AT YOUR SERVICE 24/7 – OUR VIRTUAL BOOTH

With impressive features like animated shots, clickable hotspots, and rotatable 3D models, we are confident our online presentations will truly impress you.

<https://sedirolugroup.com/products>



DISCOVER MORE ABOUT THIS PRODUCT

Scan the QR code to access detailed technical specifications, application insights, high-quality visuals, and interactive digital content related to this product.

<https://sedirolugroup.com/products/diverter-valve-dual-way>



HEAD OFFICE:
SEDIROGLU GROUP
Turkey, Çorum
T +90 541 620 03 22
E Mail : info@sedirolu.com
E Mail : info@sedirolugroup.com

www.sedirolugroup.com

Sedirolu
GROUP machine